

# SURFACE MOUNT LED SPOTLIGHT

EAUSSMBØSWC - WITH SPOT LENS

EAUSSMBØAWC - WITH REFRACTIVE LENS



Please see reverse for  
Technical Specifications

ALTHOUGH THIS LIGHT IS SHOWN MOUNTED TO A PUSH BUMPER IT CAN ALSO BE MOUNTED TO ANY FLAT SURFACE WHERE SPOT LIGHTING IS REQUIRED.

## Important Information:

- Warning devices are strictly regulated and governed by Federal, State and Municipal ordinances. These devices shall be used ONLY on approved vehicles. It is the sole responsibility of the user of these devices to ensure compliance.
- DO NOT connect this device to a strobe power supply. This product is self-contained and does not require an external power supply.

## INSTALLATION:

The orientation of the SURFACE MOUNT LED SPOTLIGHT is optional if the spot lens (EAUSSMBØSWC) is installed. The light may be inverted or installed horizontally. If the refractive lens (EAUSSMBØAWC) is used the arrows must point to the front of the vehicle for proper installation.

- 1) Determine a clean, flat location on the vehicle to mount the SURFACE MOUNT LED SPOTLIGHT.
- 2) Using the template provided on the reverse side of this page mark and drill appropriate holes as shown on the same surface that the warning light will be in contact with. Note that every effort has been made to make a full scale template but variances may occur. It is the responsibility of the installer to ensure accurate dimensions.
- 3) Drill the 2- $\varnothing 7/32$ " holes for the 10-24 carriage bolts.
- 4) Drill a  $\varnothing 3/8$ " hole for the cable to pass through the web of the push bumper. Note: this hole must be free of burrs and sharp edges to prevent damage to the wires.
- 5) Insert cable through  $\varnothing 3/8$ " hole and insert carriage bolts through  $\varnothing 7/32$ " holes.
- 6) Place flat washer, lock washer and nut on carriage bolts and tighten using reasonable force. DO NOT OVER-TIGHTEN!
- 7) Make electrical connections.

**Important!** The cable from the back of the light must be straight and relaxed for approximately the first inch. This is necessary to maintain the integrity of the light and comply with warranty.

## OPERATION:

Connect RED wire to +10-30Vdc source either direct or through a flasher (see recommended flasher on reverse side).

Connect BLACK wire to ground (-).

### Wire Diagram

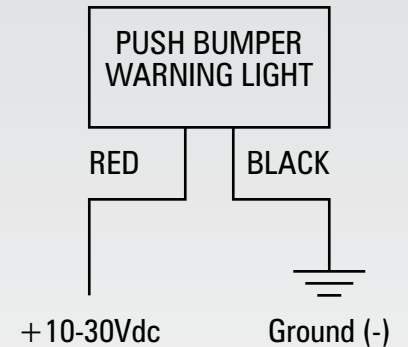

See reverse side for recommended flasher

### WIRE HOOK-UP TABLE

WIRE COLOR:	CONNECT TO:
RED	+10-30Vdc
BLACK	Ground (-)

**⚠ WARNING**

This product contains high intensity LED devices. To prevent eye damage, DO NOT stare into the light beam at close range.



To review our Limited Warranty Statement & Return Policy for this or any SoundOff Signal product please visit our website at [www.soundoffsignal.com](http://www.soundoffsignal.com) and select the "Warranty & Returns" link along the left column of our home page. If you have questions regarding this product please contact Technical Services, Monday - Friday, 8 am to 5 pm at 1.800.338.7337, press #4 to skip the automated message. Questions or comments that do not require immediate attention may be emailed to [techsupport@soundoffsignal.com](mailto:techsupport@soundoffsignal.com).

1.800.338.7337. / [www.soundoffsignal.com](http://www.soundoffsignal.com) / Thank you for trusting us with your safety!

# SURFACE MOUNT LED SPOTLIGHT

EAUSSMBØSWC - WITH SPOT LENS

EAUSSMBØAWC - WITH REFRACTIVE LENS

The drill pattern below is for use with the refractive lens (EAUSSMBØAWC). If the spot lens (EAUSSMBØSWC) is used this can be disregarded. HOWEVER, if there is a possibility of using the refractive lens in the future it is recommended that these patterns be used to prevent future additional drilling.

TECHNICAL SPECIFICATIONS	
Overall Dimensions:	4-1/8"H x 2-27/32"W x 1-15/32"D
Input Voltage Range:	10 - 30Vdc
Current Consumption:	0.65A@12.8Vdc
# of LEDs:	1 High Density Multi-Chip LED
Operating Temperature:	-40° to +65° C

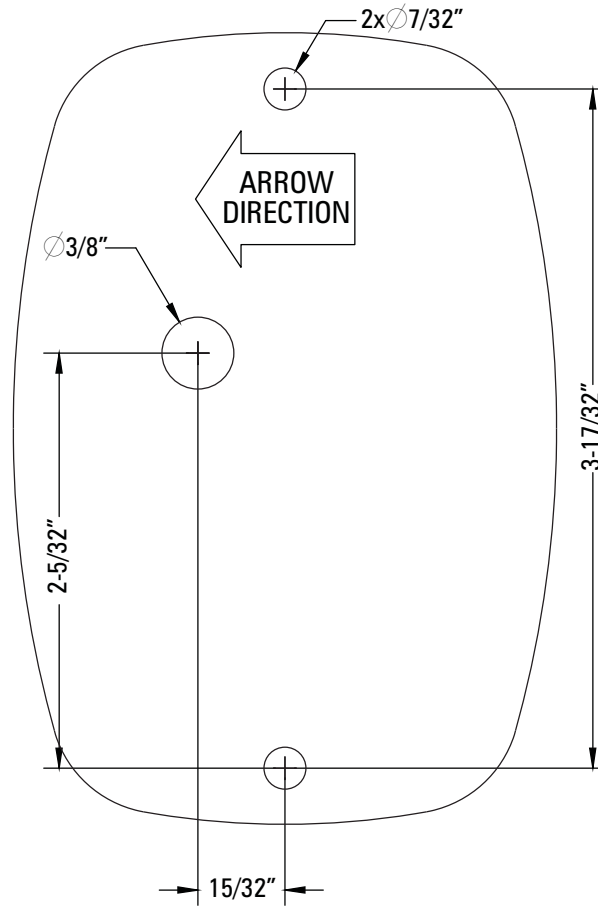

DRIVER SIDE

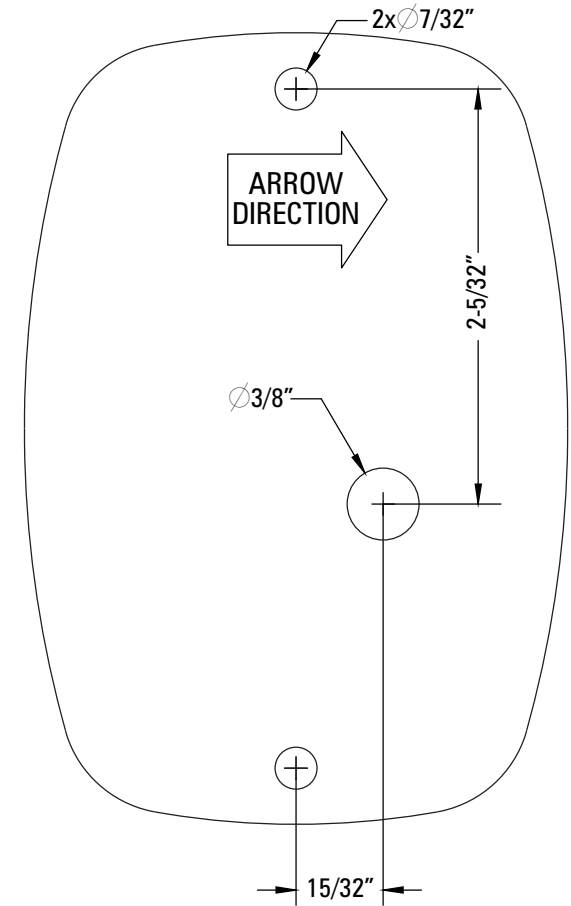

PASSENGER SIDE

Replacement Parts & Accessories: \_\_\_\_\_

ETFFCØ2LED: 10-30v Flasher



The line below should measure EXACTLY 3" if you want to use the template above to drill mounting holes. If it measures differently the installer must enlarge or reduce the page on a copier capable of such scaling.