



DUAL STROBE SELF CONTAINED WINDSHIELD LIGHT (FOR INTERIOR USE ONLY) E28HAB(x)

3900 Central Parkway
Hudsonville, MI 49426
toll free 800.338.7337
office 616.896.7100
techsupport@soundoffsignal.com
www.soundoffsignal.com

REPLACEMENT PART ORDER INFORMATION

	QTY	PART#	DESCRIPTION
1	1	PBPHG28G	DUAL LIGHT HOUSING
2	1	PPSB283	DUAL STROBE POWER SUPPLY
3	1	PWSLS24	DUAL LIGHT SHIELD
4	1	PLS248RA	LINEAR TUBE ASSEMBLY
5	1	PLE248A	AMBER LENS / GASKET / SCREWS
5	1	PLE248B	BLUE LENS / GASKET / SCREWS
5	1	PLE248C	CLEAR LENS / GASKET / SCREWS
5	1	PLE248G	GREEN LENS / GASKET / SCREWS
5	1	PLE248R	RED LENS / GASKET / SCREWS
6	1	PZBKT248	ONE "Z" BRACKET W/ HARDWARE KIT
7	1	PUC248	CIGARETTE LIGHTER ASSEMBLY
8	1	PESAWB-P	WINDSHIELD BUTTON
9	1	PESABC-P	"T" BRACKET - BALL ASSEMBLY
10	1	PESAAP-P	WINDOW ADHESIVE KIT (NOT SHOWN)

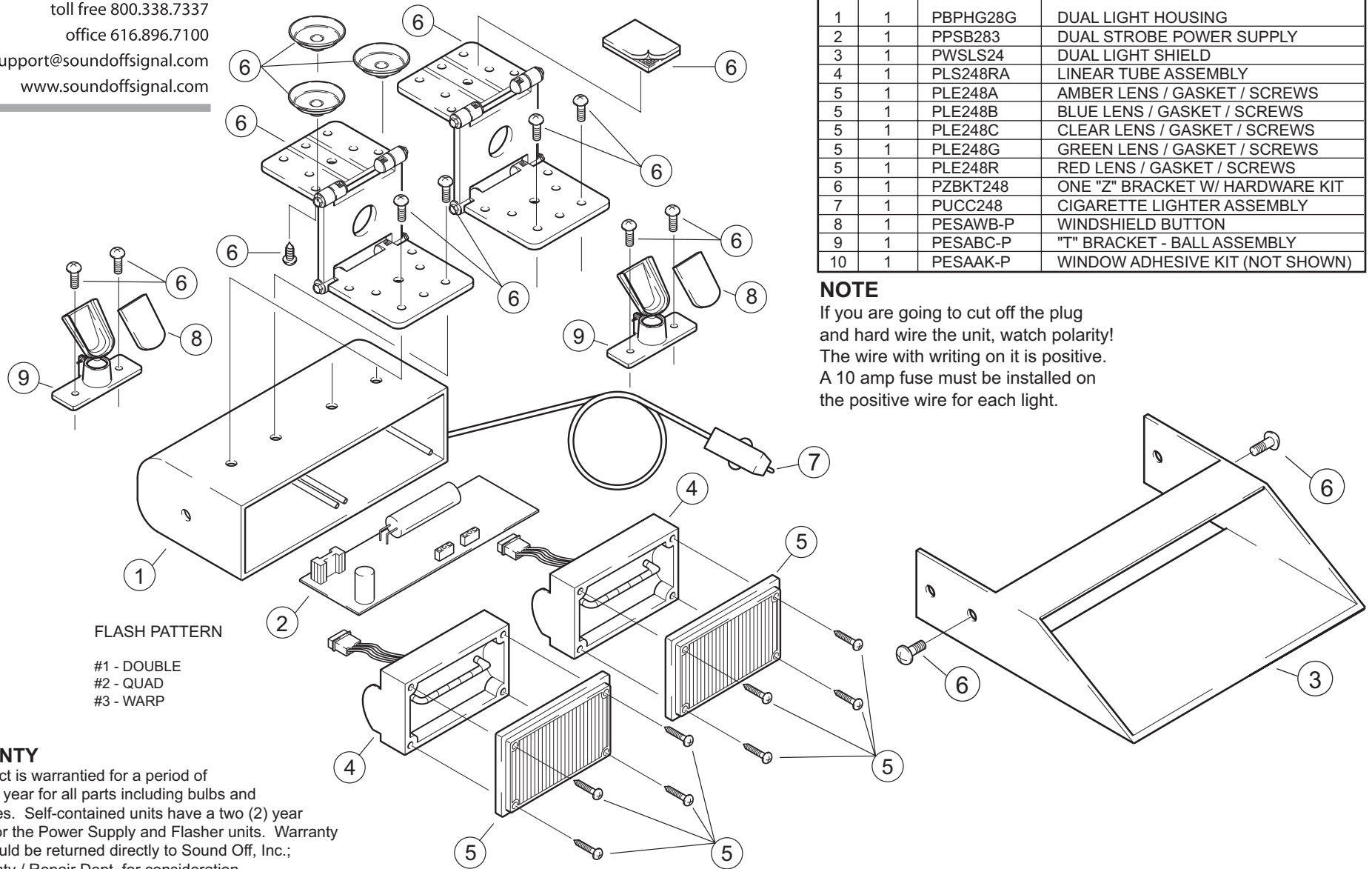

FLASH PATTERN

- #1 - DOUBLE
- #2 - QUAD
- #3 - WARP

WARRANTY

This product is warrantied for a period of one (1) full year for all parts including bulbs and strobe tubes. Self-contained units have a two (2) year warranty for the Power Supply and Flasher units. Warranty claims should be returned directly to Sound Off, Inc.; Att: Warranty / Repair Dept. for consideration. No Return Authorization is required.

NOTE

If you are going to cut off the plug and hard wire the unit, watch polarity! The wire with writing on it is positive. A 10 amp fuse must be installed on the positive wire for each light.