



3900 Central Parkway
Hudsonville, MI 49426
toll free 800.338.7337
office 616.896.7100

techsupport@soundoffsignal.com
www.soundoffsignal.com

The ETSS100E Siren Loudspeaker is used for high powered transmission of electronic siren and voice communications in vehicular applications. It is suitable for installation within lightbars, engine compartments or for mounting in front of the radiator or on the bumper of any ambulance, fire, law enforcement, utility or other public service vehicle. It is furnished with a one piece steel mounting bracket and has a field-replaceable driver-head assembly. Field terminations are via 20" (508mm) 18ga, color-coded wire leads. The leads are **RED** and **BLACK**. The **RED** lead is connected to the #2 positive driver terminal.

SIREN LOUDSPEAKER ETSS100E



WARNING: Warning devices are strictly regulated and governed by Federal, State and Municipal ordinances. These devices shall be used **ONLY** on approved vehicles. It is the sole responsibility of the user of these devices to ensure compliance.

SAFETY MESSAGE TO OPERATORS AND INSTALLERS OF SOUNDOFF SIGNAL SIREN/SPEAKER SYSTEMS.

Signaling Limitations:

Sirens/speakers provide an essential function of an effective audio-visual warning system. However, sirens are only short range secondary devices. The use of a siren/speaker system does not insure that all drivers can or will abide by or react to an emergency warning signal, especially at high rates of speeds or long distances. The operator of the vehicle must never take the right of way for granted and it is the operator's responsibility to proceed safely.

The effectiveness of the siren/speaker system is highly dependant on the correct mounting and wiring. The installer must read and follow manufacturer's installation instructions and warnings in the manual. The vehicle operator should verify the siren/speaker system is securely fastened to the vehicle and properly functioning.

Maximum sound output will be severely reduced if any objects are in front of the speaker. If your installation has obstructions in front of the speaker, drive even more cautiously.

Sound Hazards:

Effective siren/speaker systems generate loud sound pressure levels (120db) that can potentially cause permanent hearing damage. Installers and those around the vehicle need to be aware of the dangers and wear hearing protection whenever the siren system is operating.

Vehicle operators and occupants should asses their exposure to siren noise and determine what steps need to be taken to prevent hearing damage. For hearing conservations guidance, refer to federal, state, or local recommendations. OSHA Standard 1910.95 offers guidance on Permissible Noise Exposure"

Qualifications:

To properly install a siren, you must have a good understanding of automotive systems, electronics and procedures.

The siren/speaker system is intended for use by authorized personnel only. The user's responsibility to ensure they understand and operate the emergency warning devices in compliance with all applicable city, state, and federal laws and regulations and have a thorough knowledge of state and federal UNIFORM TRAFFIC CODES.

Soundoff Signal assumes no liability for any loss resulting in the use of this warning device

During Installation:

Do not get metal shavings inside of speaker. Metal shavings can cause speaker to fail. If metal removing must be done near the speaker, place a cover over the unit to prevent metal shavings from getting inside of speaker.

Do not route speaker wires where they may interfere with the operations or deployment of the air bag or it's sensors. Equipment mounted near the air bag deployment area will damage or reduce the effectiveness of the air bag. The user/installer assumes full responsibility to determine proper mounting location, based on providing safety for passengers inside the vehicle.

After Installation:

Test the siren and light system to ensure that everything is operating properly.

Test all vehicle functions to ensure that installation has not affected vehicle operation or changed vehicle safety function.

Store these instructions in a safe place and refer to them when performing maintenance and/or reinstallation of product.

Note: The weep hole located in the front of the driver must be positioned at 6:00 o'clock when installed.



WARNING
Sirens produce loud sounds that may damage hearing

- Roll up windows
- Wear hearing protection
- Use only for emergency response
- Avoid exposure to siren sound outside of vehicle

MODEL	POWER RATING	IMPEDANCE	FREQ. RESPONSE	DISPERSION
ETSS100E	100 Watts RMS	11 Ohms Nominal	450-3500 Hz +/-10dB Nominal	80° x 105° 1KHz Octave Band



3900 Central Parkway
Hudsonville, MI 49426
toll free 800.338.7337
office 616.896.7100

techsupport@soundoffsignal.com
www.soundoffsignal.com



⚠ WARNING

Sirens produce loud sounds that may damage hearing

- Roll up windows
- Wear hearing protection
- Use only for emergency response
- Avoid exposure to siren sound outside of vehicle

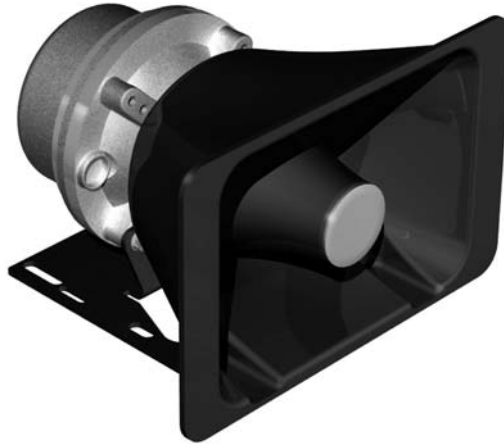

SIREN LOUDSPEAKER ETSS100E

