

UNDERCOVER™ STROBE HEAD ETUC0(x)-P

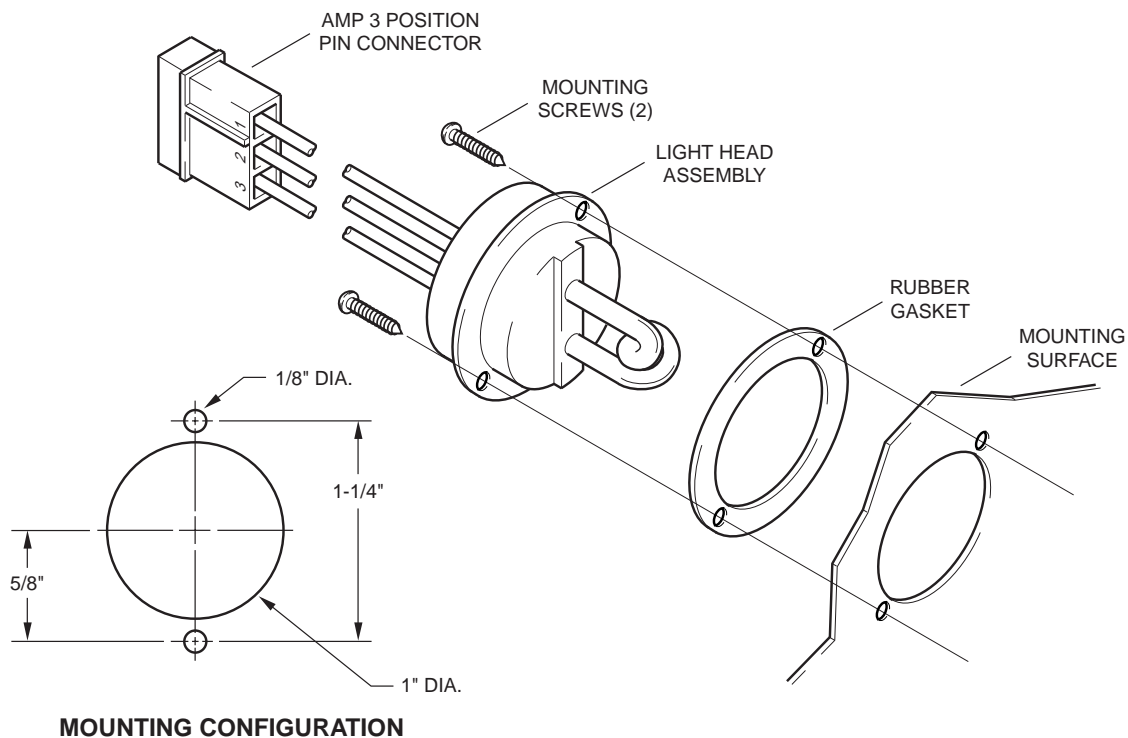

WARNING

High Voltage on the surface of the glass tube. The Undercover Strobe Light Head is a open flash tube with NO protective lens. Proper installation is required. **DO NOT TOUCH STROBE TUBE OR THE STROBE TUBE ASSEMBLY WHEN IN OPERATION!**

"COMPOSITE" AUTOMOTIVE HEADLIGHT, CORNER LIGHT OR TAIL LIGHT INSTALLATION USING AN UNDERCOVER STROBE LIGHT HEAD.

1. Since the Undercover Strobe Light Head will share the same reflector as the headlight, brake light or corner light, make sure the Undercover Strobe Tube does not interfere with the proper operation of the currently existing lights.

2. After taking the "Composite" reflector assembly from the vehicle, select a surface in the rear or bottom of the "Composite" housing which is as flat as possible and cut a 1" hole. Use the Strobe Light Head gasket as a template to mark the location of the two mounting screws. Mount the Strobe Light to the housing.

3. After selecting the best location for the Strobe Power Supply (refer to the Power Supplies Instructions), string the 3 conductor cable (Figure A) from the Power Supply location to the remote Strobe Light Head.

NOTE

The end of the 3 conductor cable with the closed tip terminals (male pins) are to be connected to the Strobe Power Supply and the open ended terminals (female sockets) are to connect to the Strobe Light Head Assembly.

Make sure the strobe cable is secure along the chosen cable routing inside the vehicle to prevent it from damage by chafing or stretching. When used to connect Strobe Lights located in the front of the vehicle, such as head lights, be sure to keep the cable away from engine HOT spots.

WARNING

Strobe Tubes generate HIGH heat. Be certain to install Undercover Tubes into a light housing of sufficient size to dissipate the heat.

4. Install the amp 3 socket housing onto the end of the 3 conductor power cable to be connected to the Undercover Remote Strobe Light Head Assembly, see Figure A. Connect the cable and light first.

5. Install the amp 3 socket housing onto the end of the 3 conductor power cable to be connected to the Strobe Power Supply, see Figure A. Connect this cable to one of the Strobe Light outlets located on the Strobe Power Supply. Repeat the installation instructions for the other remaining Strobe Light Heads. Connect the Strobe Power Supply to the power source as indicated in the instructions enclosed with the Power Supply. Test the system.

NOTE

This testing may be performed before securing the remote Strobe Light Head Assembly to the mounting surface of the "Composite" housing assembly as described in Section 2.

WARNING

OBSERVE THE COLOR OF THE WIRES TO BE CONNECTED TO PIN NUMBER POSITIONS when connecting the amp connector housings to the amp pins and sockets, see Figure A.

IMPORTANT CABLE INFORMATION

The cable supplied with the Undercover Strobe Head is a shielded type with a length of shield wire exposed on each end. On the end of the cable at the Undercover Strobe Head, cut the shield flush with the cable jacket. On the other end of the cable, by the Power Supply, the shield wire is to be grounded to the vehicle chassis to reduce radio or other communication system interference. ALWAYS KEEP THIS WIRE AS SHORT AS POSSIBLE WHEN GROUNDING. If this ground shield wire is not to be installed, cut it flush with the cable jacket.

NOTE

SoundOff Signal Strobe Light Systems are designed to interface with SoundOff Signal Strobe Light Power Supplies. They are also 100% field compatible with Whelen and Tomar Power Supplies, cables and light heads. Detailed wiring, switching and installation instructions are enclosed with the Strobe Light Power Supply.

WARNING

The Strobe Power Supply is a high voltage device, therefore DO NOT remove Strobe Tubes or dismantle light heads while unit is operating. **ALWAYS WAIT TEN MINUTES AFTER TUNING OFF THE POWER BEFORE STARTING ANY TROUBLE SHOOTING.**

⚠ WARNING

PERSONAL INJURY HAZARD

Mounting this device in an improper location may impair the designed safety characteristics of the vehicle in the event of a collision.

Consult the vehicle manufacturer before installing this or any other aftermarket device to determine its proper mounting location.

Failure to consult and follow the vehicle manufacturer's mounting recommendations may result in serious personal injury or death.

To Reduce EMI emissions, ONE end of the shield (drain wire) of the extension cable connecting the output of the power supply to the Lighthouse should be connected to ground. Make sure ONLY ONE END of the shield is tied to ground. The other end needs to be taped or cut.

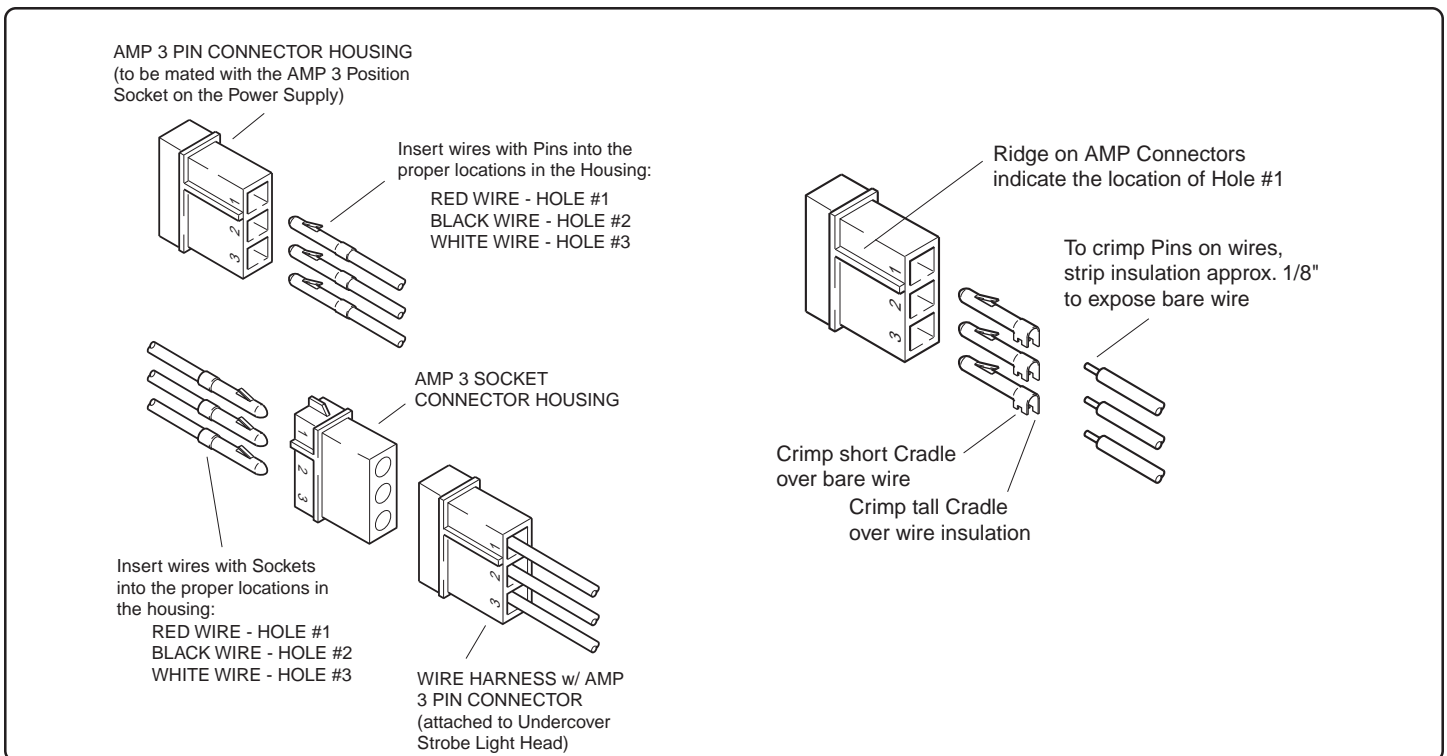

Figure A.