

AURORA™ STROBE POWER SUPPLY

WARNING

High Voltage! Please wait 5 minutes after shutting this unit OFF before attempting service.

(ETA225)

NOTE

To extend the power (+) and ground (-) wires, use the following as a guide.

1 to 20 ft. use 18AWG wire
20 to 50 ft. use 16AWG wire

STROBE POWER SUPPLY SPECIFICATIONS

Voltage	10-14 Vdc
Current	2.5 Amps @ 12.8 Vdc
Power	25 Watts
Fuse	10 Amp - User Supplied
Number of Heads	2

INSTALLATION

1. Install the strobe light heads in the preferred locations.
2. String the 3-conductor cables between the lights and the power supply. Make sure the cable is secure along the chosen routing inside the vehicle to prevent it from damage by chafing or binding. Be sure to keep the cable away from engine hot spots.

NOTE

When routing the cable, make sure the end with the closed tip terminals (male pins) is toward the power supply and the end with the open tip terminals (female pins) is toward the light head.

3. Insert the pins on each end of the conductor cables into the connectors. Each end of these cables has a factory crimped pin on each of the three wires, see Figure B or C.

NOTE

It is important to follow the correct color code when inserting the pins into the connectors.

4. Connect the cables to the strobe light heads.
5. Next, plug the other end of the cable into the Light Head Output Socket on the Strobe Power Supply
6. Connect the red wire to the user supplied switch along with the blue and/or green wires to get desired pattern, see Figures A, D and E.
7. Connect the black wire to a reliable ground.

FLASH	BLUE	GREEN	FPM
QUAD			70
WARP	POWER		350
QUINT		POWER	70
DOUBLE	POWER	POWER	140

Figure A.

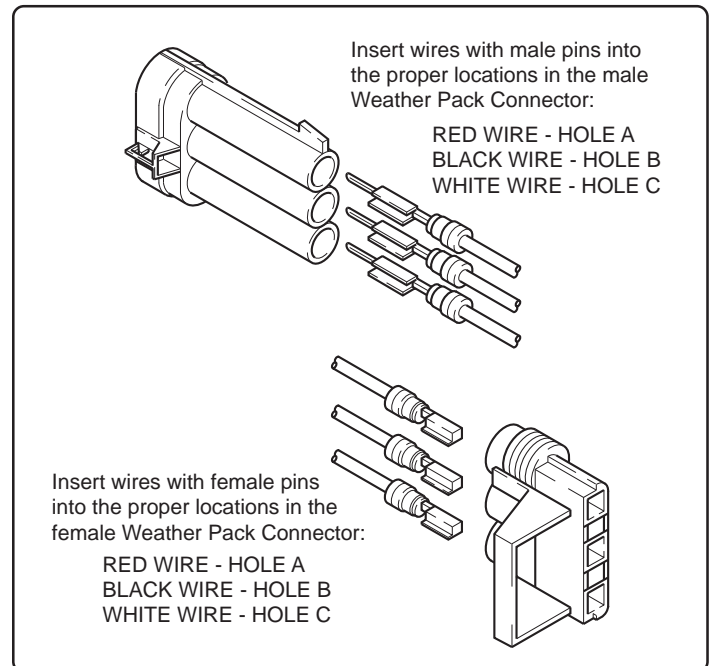

Figure B. Weather Pack Connectors for use with
ETA225-WP

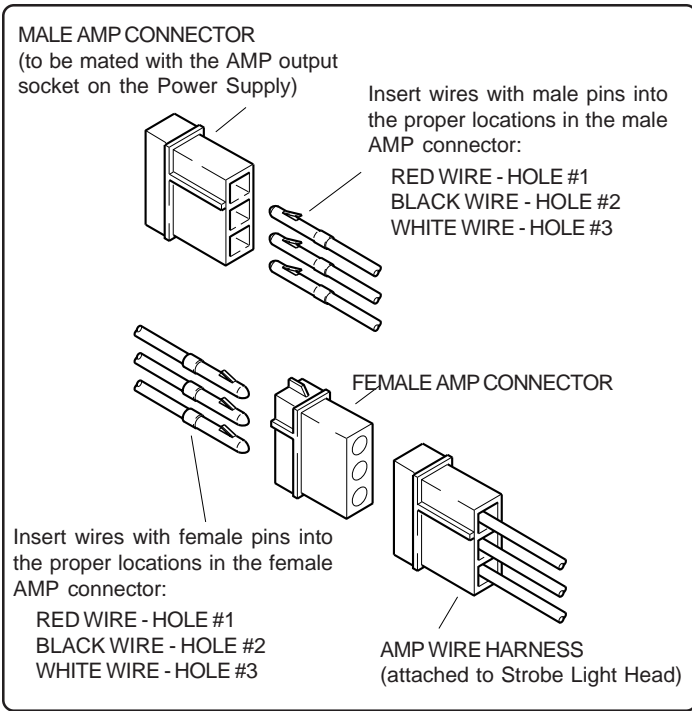

Figure C. Amp Connector for use with ETA225-P

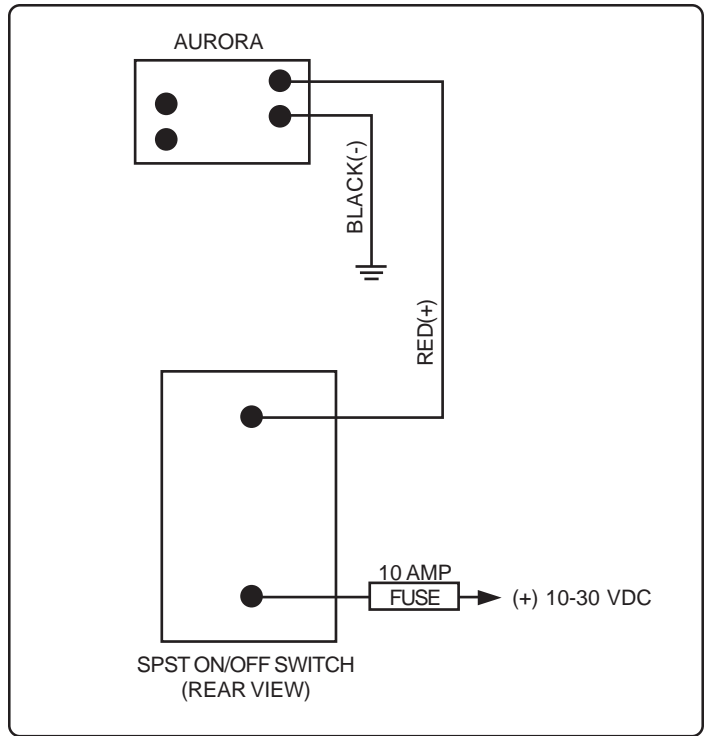

Figure E. Quad Flash

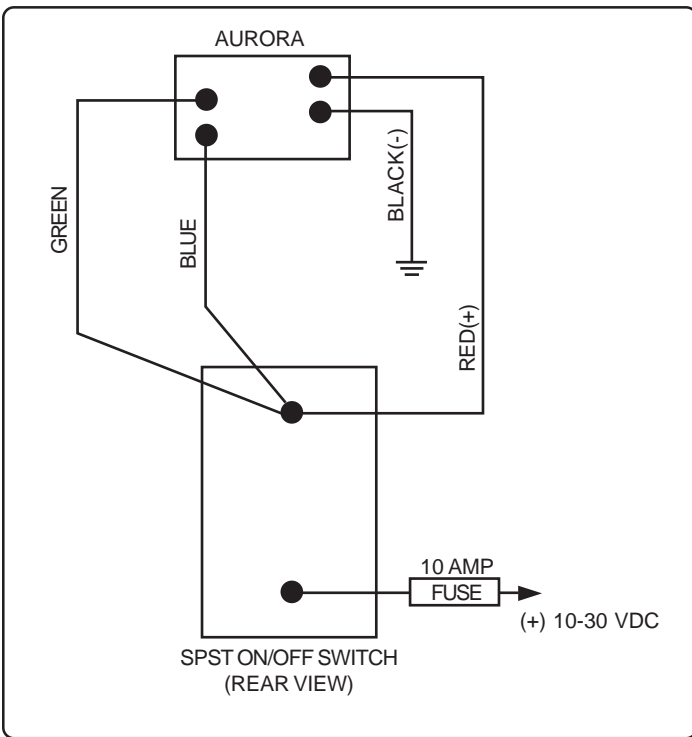

Figure D. Double Flash

To Reduce EMI emissions, ONE end of the shield (drain wire) of the extension cable connecting the output of the power supply to the Lighthouse should be connected to ground. Make sure ONLY ONE END of the shield is tied to ground. The other end needs to be taped or cut.

WARRANTY

SoundOff Signal warrants the ETA225 Remote Strobe Power Supply for 1 (one) full year from date of purchase, to the original purchaser, against any manufactured defects or workmanship. This warranty applies only to units installed according to manufacturer's installation instructions and operated within the units specifications.

Warranty is void if the unit was installed incorrectly or maliciously damaged.

All warranty claims must be accompanied by a dated proof of purchase.

SoundOff Signal retains the right to be the sole mediator of what constitutes defects in performance or manufacturing.

⚠ WARNING

PERSONAL INJURY HAZARD

Mounting this device in an improper location may impair the designed safety characteristics of the vehicle in the event of a collision.

Consult the vehicle manufacturer before installing this or any other aftermarket device to determine its proper mounting location.

Failure to consult and follow the vehicle manufacturer's mounting recommendations may result in serious personal injury or death.