

FLASHBACK™ ALTERNATING TAILLIGHT FLASHER

ETFBSSN-P

ETFBSAN-P (w/ AMP Connector)

ETFBSANFL (w/ Fleet Harness)

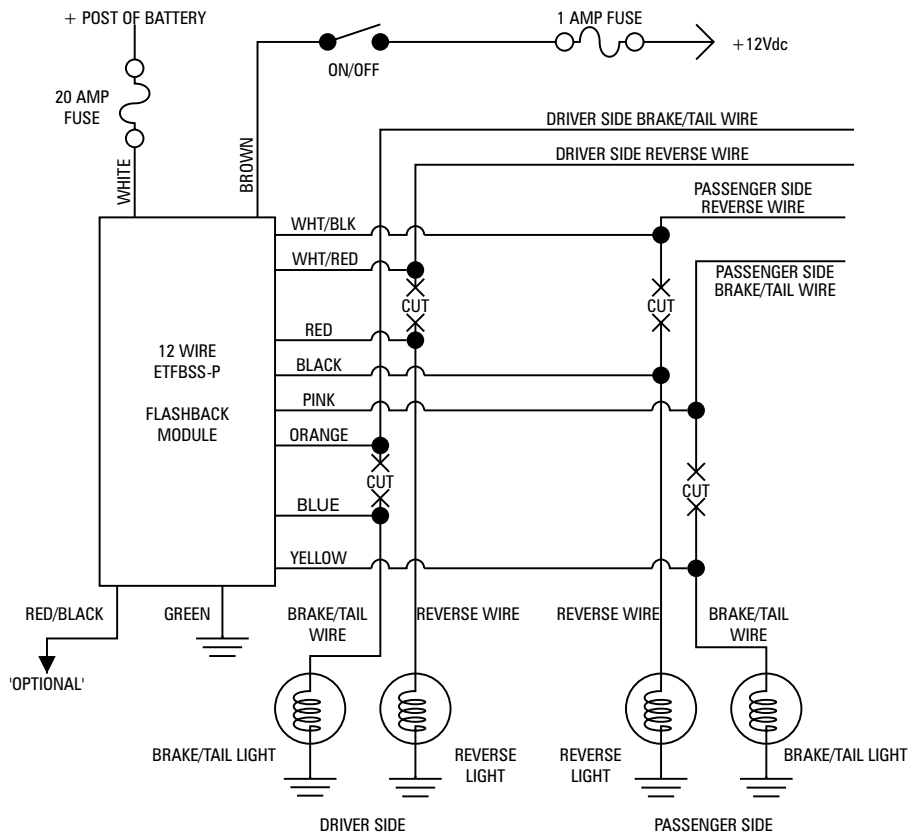

WARNING

DO NOT Connect the ETFBSSN-P Taillight Flasher to the High Mounted-Stop Lamp (i.e. "Cyclops", "Center Light", "CHMSL"). Flashing the High Mounted Stop Lamp violates Federal Motor Vehicle Safety Standard (FMVSS) No. 108 which requires the High Mounted Stop Lamp only illuminate when applying the brakes.

Please see reverse for Technical Specifications



CAUTION

Some vehicle manufacturers may NOT allow the use of this product on vehicles that they manufacture. Please consult your operator's manual prior to installation. Also, make sure you fully read and understand all instructions before attempting to install the Flashback Flasher.

The SoundOff Signal 100% Solid State ETFBSSN-P 12 wire Flashback module has the isolating diodes for the reverse wire that is now required by many new cars and trucks. This module is intended to be used on vehicles that have the negative post of the battery connected to the chassis of the vehicle.

A properly installed flashback will alternately flash the brake lights and the reverse lights at a rate of 2.4 flashes per second. Alternating red and white light creates an effective warning signal to the rear of the vehicle to greatly reduce rear end collisions.

INSTALLATION MOUNTING:

For vehicles with a trunk, mount the flashback as close to the driver side taillight housing as possible. For vehicles with a tailgate or lift gate, mount the flasher as close to the taillight housing on the driver side. For pickup trucks, remove the driver side taillight housing and mount the flasher behind the taillight housing.

CONNECTIONS:

Connect the GREEN WIRE to a convenient reliable ground.

Extend the WHITE WIRE from the module using 14 gauge wire. This wire must go all the way to the battery. Connect a fuse holder to the positive post of the battery. The fuse holder must be rated at 20 amps or greater. Connect the 14 gauge extension wire to the fuse holder.

NOTE: Failure to extend the White wire to the battery with 14 gauge wire will result in improper operation and may cause damage to the flasher or other devices in the vehicle.

NOTE: DO NOT INSTALL THE FUSE UNTIL ALL OTHER CONNECTIONS HAVE BEEN COMPLETED.

Use 18 gauge or larger wire to extend any other wires as needed.

Driver Side Connections:

Locate and cut the brake light wire. Connect the BLUE WIRE from the flasher to the end that goes to the brake light. Connect the ORANGE WIRE from the flasher to the end that goes to the front of the vehicle.

Locate and cut the reverse light wire. Connect the RED WIRE from the flasher to the end that goes to the reverse light. Connect the WHITE/RED WIRE from the flasher to the end that goes to the front of the vehicle.

Passenger Side Connections.

Extend the YELLOW, PINK, WHITE/BLACK and BLACK WIRE over to the passenger side of the vehicle.

Locate and cut the brake light wire. Connect the YELLOW WIRE from the flasher to the end that goes to the brake light. Connect the PINK WIRE from the flasher to the end that goes to the front of the vehicle.

Locate and cut the reverse light wire. Connect the BLACK WIRE from the flasher to the end that goes to the reverse light. Connect the WHITE/BLACK WIRE from the flasher to the end that goes to the front of the vehicle.

Extend the BROWN WIRE from the flasher to a powered switch that will turn the flasher on and off. It is recommended to have a fuse holder connected to the powered switch with a 1 amp or smaller fuse. This is needed to protect the wire between the switch and the flasher module.

RED / BLACK WIRE: Auxiliary Output to control Package Tray Lights. See Package Tray Lighting Installation on reverse side of sheet.

To review our Limited Warranty Statement & Return Policy for this or any SoundOff Signal product please visit our website at www.soundoffsignal.com and select the "Warranty & Returns" link along the left column of our home page. If you have questions regarding this product please contact Technical Services, Monday - Friday, 8 am to 5 pm at 1.800.338.7337, press #4 to skip the automated message. Questions or comments that do not require immediate attention may be emailed to techsupport@soundoffsignal.com.

1.800.338.7337. / www.soundoffsignal.com / Thank you for trusting us with your safety!

FLASHBACK™ ALTERNATING TAILLIGHT FLASHER

ETFBSSN-P

ETFBSAN-P (w/ AMP Connector)

ETFBSANFL (w/ Fleet Harness)

ELECTRICAL SPECIFICATIONS	
Input Voltage	10-16Vdc
Output Current:	5 Amps / output
Standby Current:	< 10mA
Flash Frequency:	2.4 f.p.s.

IMPORTANT TEST Vehicle Safety Systems and Flasher.

1. Set emergency / parking brake and start the vehicle.
2. With Flasher OFF, attempt to shift the transmission out of PARK without depressing the brake. TRANSMISSION MUST NOT SHIFT. If the vehicle shifts from PARK, disconnect the Flasher, restore vehicle wiring and contact SoundOff Signal Technical Service Department for further instructions.
3. With Flasher ON, attempt to shift the transmission out of PARK without depressing the brake. TRANSMISSION MUST NOT SHIFT. If the vehicle shifts from PARK, disconnect the Flasher, restore vehicle wiring and contact SoundOff Signal Technical Support Department for further instructions.
4. Periodically have the operator of the vehicle repeat the above test to ensure proper operation of the vehicle safety systems.

