



3900 Central Parkway  
 Hudsonville, MI 49426  
 toll free 800.338.7337  
 office 616.896.7100  
 techsupport@soundoffsignal.com  
 www.soundoffsignal.com

# DUAL STROBE REMOTE DASH / DECK LIGHT (FOR INTERIOR USE ONLY) E28DSB4(x)

## REPLACEMENT PART ORDER INFORMATION

	QTY	PART#	DESCRIPTION
1	1	PBPHG28G	DUAL LIGHT HOUSING
2	1	PRFTL248	TWIST LOCK REFLECTOR
3	1	PFI35SC	TWIST LOCK STROBE TUBE
4	1	ETSC15D6	15' - 6 WIRE STROBE CABLE
5	1	PLE248A	AMBER LENS / GASKET / SCREWS
5	1	PLE248B	BLUE LENS / GASKET / SCREWS
5	1	PLE248C	CLEAR LENS / GASKET / SCREWS
5	1	PLE248G	GREEN LENS / GASKET / SCREWS
5	1	PLE248R	RED LENS / GASKET / SCREWS
6	1	PZBKT248	ONE "Z" BRACKET W/ HARDWARE KIT
7	1	PUBKT28	DUAL "U" BRACKET W/ HARDWARE KIT

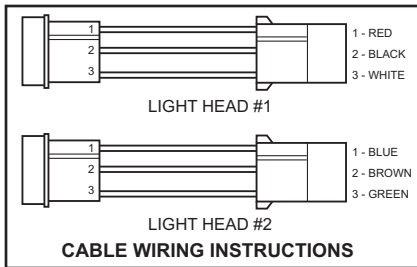
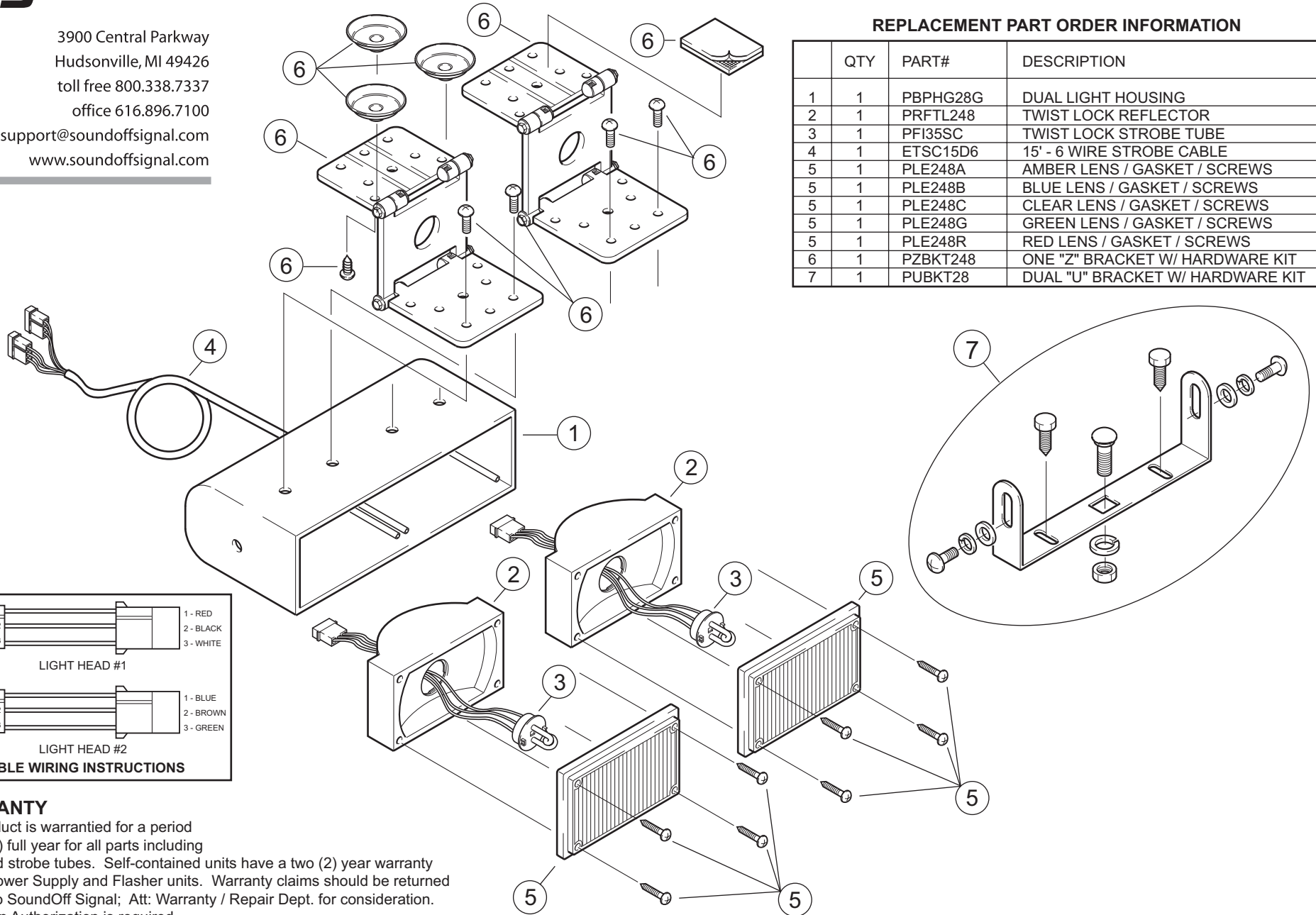

### WARRANTY

This product is warranted for a period of one (1) full year for all parts including bulbs and strobe tubes. Self-contained units have a two (2) year warranty for the Power Supply and Flasher units. Warranty claims should be returned directly to SoundOff Signal; Att: Warranty / Repair Dept. for consideration. No Return Authorization is required.