

3900 Central Parkway
Hudsonville, MI 49426
toll free 800.338.7337
office 616.896.7100
techsupport@soundoffsignal.com
www.soundoffsignal.com

DUAL STROBE SELF CONTAINED DASH / DECK LIGHT (FOR INTERIOR USE ONLY) E28DAB(x)

REPLACEMENT PART ORDER INFORMATION

	QTY	PART#	DESCRIPTION
1	1	PBPHG28G	DUAL LIGHT HOUSING
2	1	PPSB283	DUAL STROBE POWER SUPPLY
3	1	PWLS28	DUAL LIGHT SHIELD (OPTIONAL)
4	1	PLS248RA	LINEAR TUBE ASSEMBLY
5	1	PLE248A	AMBER LENS / GASKET / SCREWS
5	1	PLE248B	BLUE LENS / GASKET / SCREWS
5	1	PLE248C	CLEAR LENS / GASKET / SCREWS
5	1	PLE248G	GREEN LENS / GASKET / SCREWS
5	1	PLE248R	RED LENS / GASKET / SCREWS
6	1	PZBKT248	ONE "Z" BRACKET W/ HARDWARE KIT
7	1	PUCC248	CIGARETTE LIGHTER ASSEMBLY
8	1	PUBKT28	DUAL "U" BRACKET W/ HARDWARE KIT

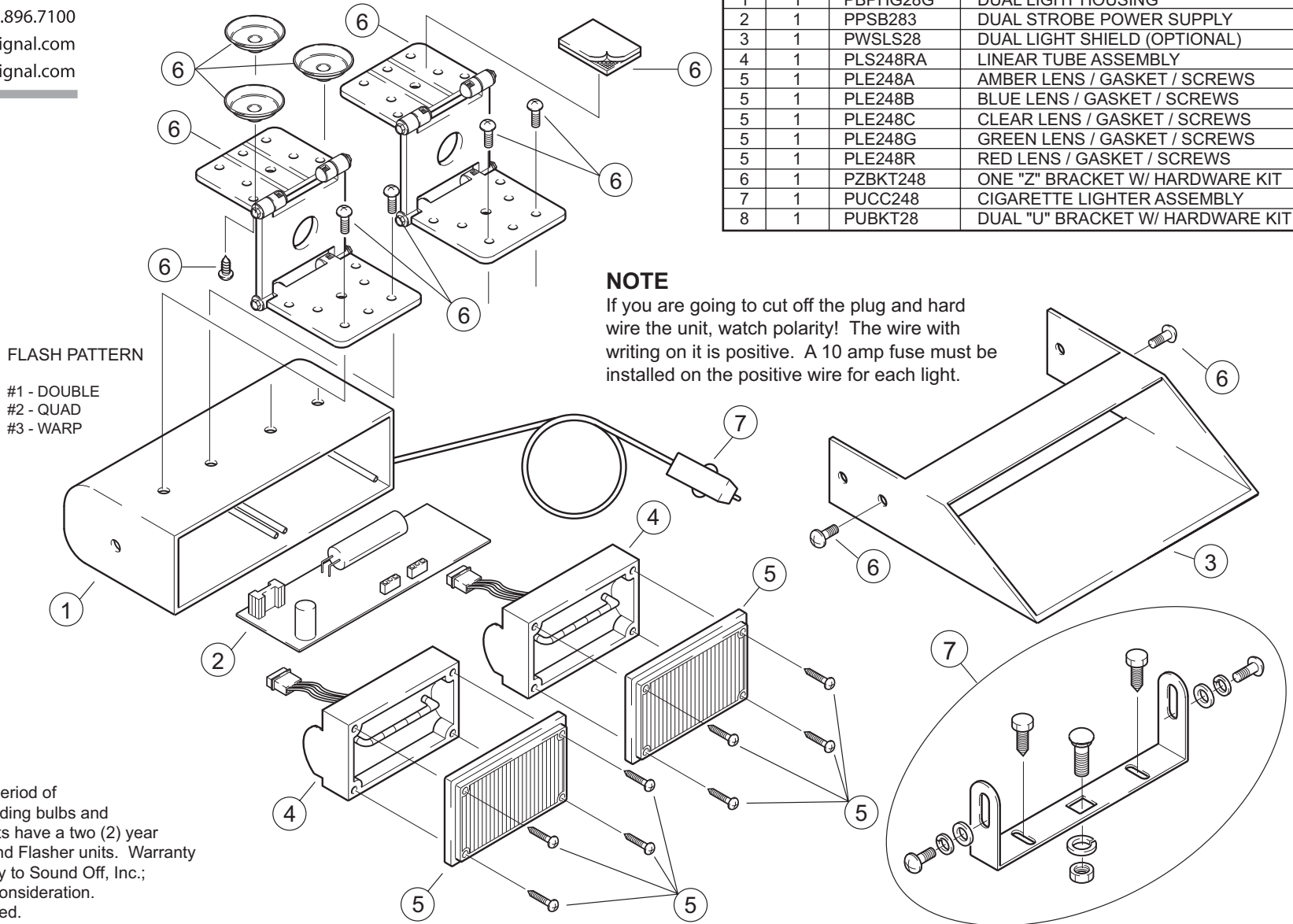

WARRANTY

This product is warranted for a period of one (1) full year for all parts including bulbs and strobe tubes. Self-contained units have a two (2) year warranty for the Power Supply and Flasher units. Warranty claims should be returned directly to Sound Off, Inc.; Att: Warranty / Repair Dept. for consideration. No Return Authorization is required.